

FM662 AVR Peripheral Board

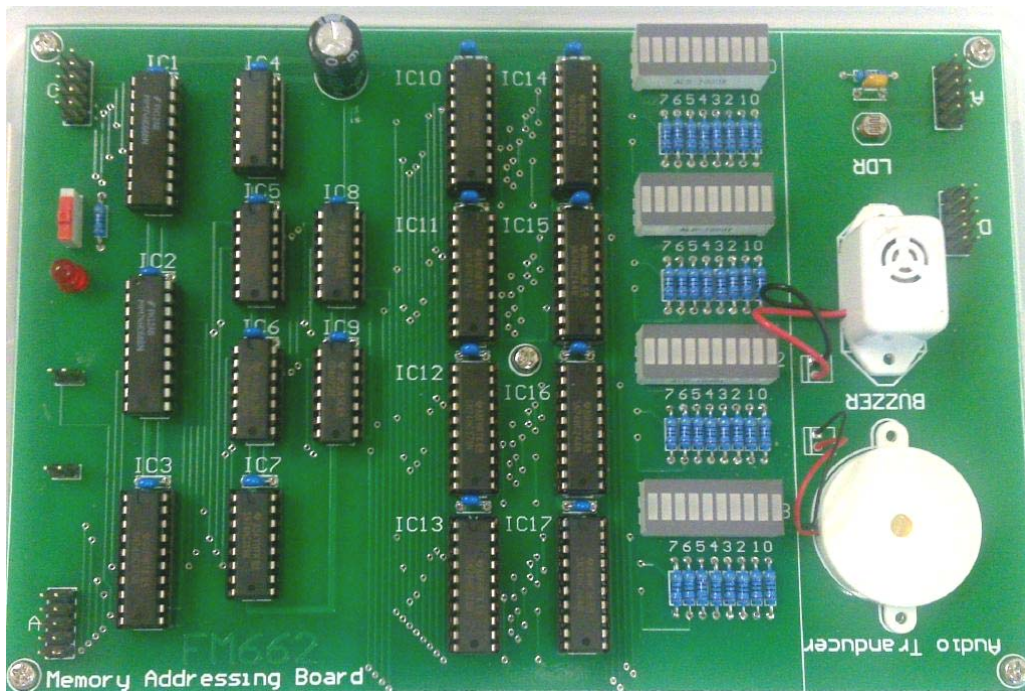

This Peripheral Board is separated into two distinct areas. The larger area on the left (pictured facing the correct way up) is the Memory Addressing Board area. This is used to illustrate how to extend the AVR's limited internal memory by adding external memory. The smaller area on the right (pictured upside-down) is the Sensor/Actuator Board area. This is used to illustrate how to communicate with sensors and actuators using analog and PWM signals.

The Memory Addressing Board has connectors for both Ports A & C (extended address bus), as well as connections for RD, WR & ALE signals (*discussed below*). The Sensor/Actuator Board has connections for Ports A & D.

All 10-pin connectors are compatible in layout with the port connectors on the STK500 development kit board and have been positioned to reduce wire entanglements. The 10-pin ribbon-cable connectors and single or dual-pin cables can be used to connect this board with the STK500 kit

Memory Address Board Area Description

The Memory Addressing Board area can be used to illustrate how to extend the AVR's limited internal memory by adding external memory. Note that this board only implements four 8-bit external memory locations (in the range 0xFF00-0xFF03), and as such is not intended to be a realistic memory expansion project.

The board implements both the memory (labelled SRAM) and the Address Latch (labelled as a D Flip-Flop) as shown in this image, taken from the AVR datasheet.

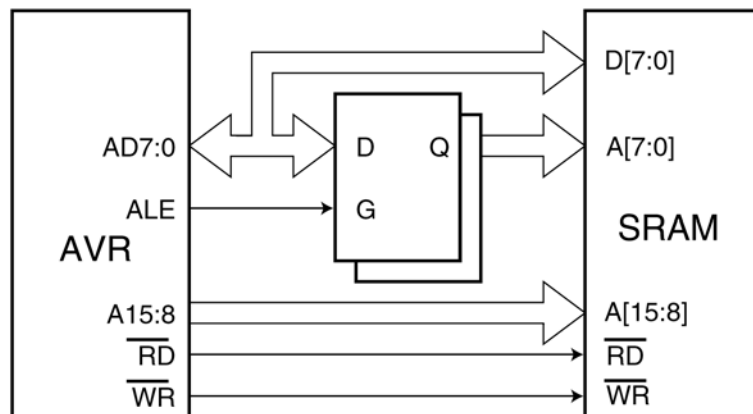

A 16-bit bus is used to communicate the Address & Data busses. These use Ports A & C. In addition, there are three signals, shown on the connector diagram below.

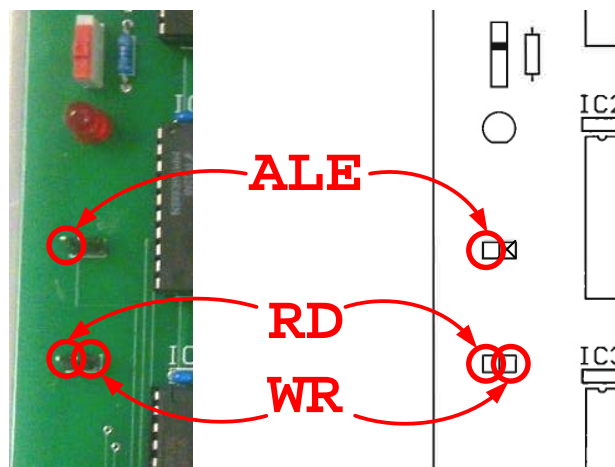

Example AVR program

Memory:

```

; Enable the external memory interface (SRE)
ldi temp, (1<<SRE)
out MCUCR, temp
:
; Output specified values to memory locations 0xFF00-3
ldi temp, 12
sts 0xFF00, temp
sts 0xFF01, temp
sts 0xFF02, temp
sts 0xFF03, temp

```

Schematics

Memory Addressing Board connections (AVR-side):

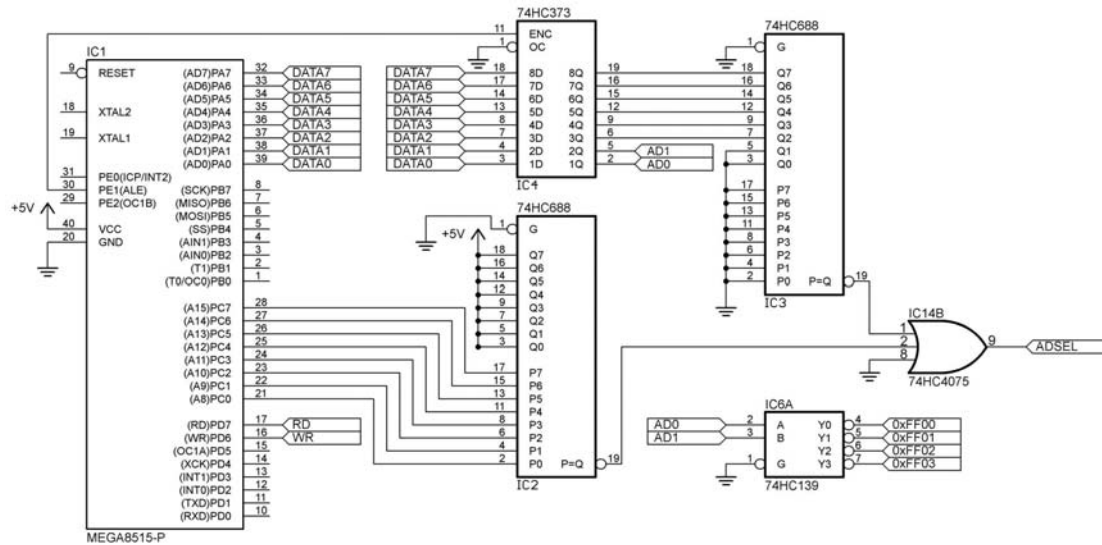

Memory Addressing Board connections (LED banks):

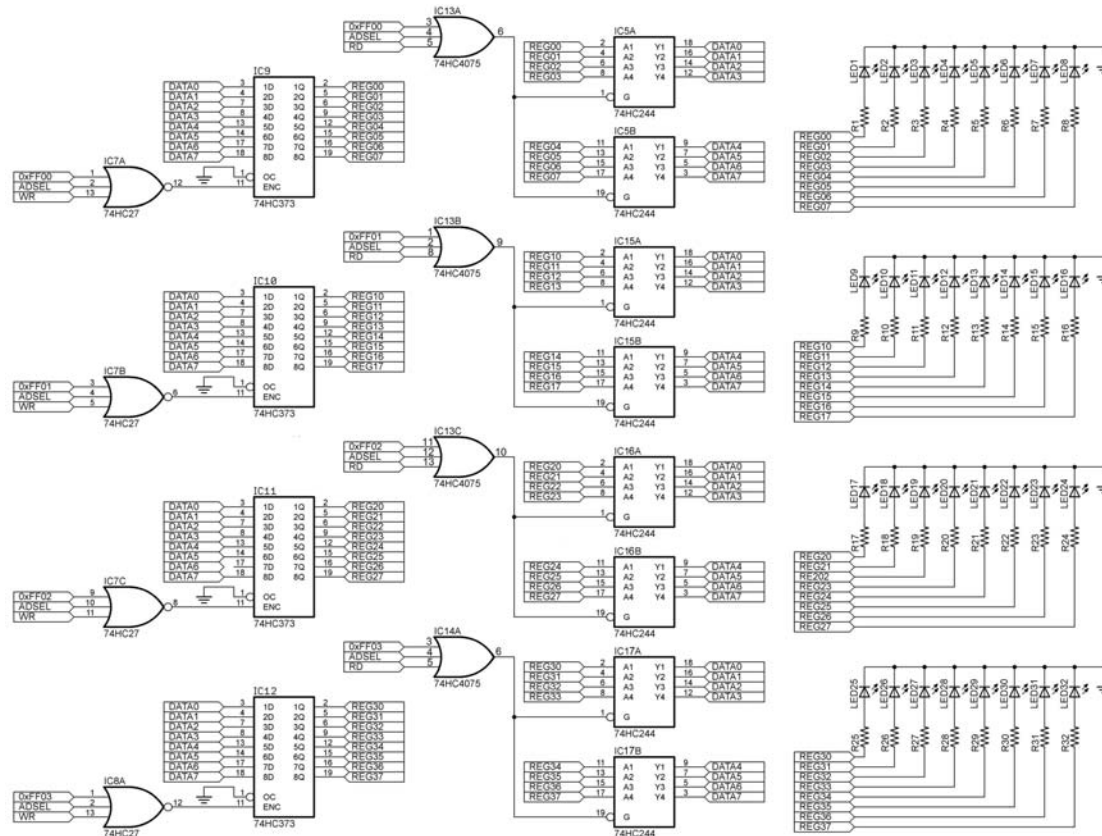

PCB Overlay:

