

Harmonic Allocation to Aggregated Regions Within a Transmission Network

T.J. Browne

Integral Energy Power Quality
and Reliability Centre
University of Wollongong
Wollongong, NSW, Australia
tim@elec.uow.edu.au

V.J. Gosbell

Integral Energy Power Quality
and Reliability Centre
University of Wollongong
Wollongong, NSW, Australia
vgosbell@uow.edu.au

S. Perera

Integral Energy Power Quality
and Reliability Centre
University of Wollongong
Wollongong, NSW, Australia
sarath@uow.edu.au

ABSTRACT

Utilising the standard AS/NZS61000.3.6 to carry out a harmonic allocation to a load in a transmission system requires detailed knowledge of the location and magnitude of every future load. Given that the size of the load at a bus in a transmission system could conceivably be from zero up to around thirty percent of the fault level, such knowledge is unlikely to be available with any degree of certainty. This paper proposes an allocation policy which reduces the effect of load uncertainty, by allocating harmonic emission levels to areas comprising buses which are electrically close. Possible techniques are demonstrated using a simple test network.

1. INTRODUCTION

Present methods of harmonic allocation in transmission networks, as described in Section 2, rely heavily on loads and network equipment being accurately modelled. Such accurate modelling, however, is rarely possible, as network configurations and parameters are continually changing. Furthermore, in contrast to a distribution system which may reach finite limits, a transmission network undergoes modification throughout its lifetime and thus does not tend towards a steady state. A particular problem is faced when modelling projected load behaviour: a customer may at some future time wish to connect a large load to a bus which is currently not loaded. Thus some provision for potential future loads must be made when carrying out a harmonic allocation. Given the substantial uncertainty associated with the location and quantity of future load, allocation of harmonics to individual buses — as required under [1] — may not be the best solution; Sections 3 and 4 provide further evidence supporting this position.

This paper explores the concept of area-based allocation, whereby the buses in a transmission network are compressed into electrically close areas. Instead of harmonic voltage being allocated to individual buses, it is allocated to a group of buses in one of the defined areas. Section 5 provides a method of identifying particular areas within a network, while Section 6 describes a method of carrying out an area-based allocation.

To demonstrate results, a simple 230/115kV test network

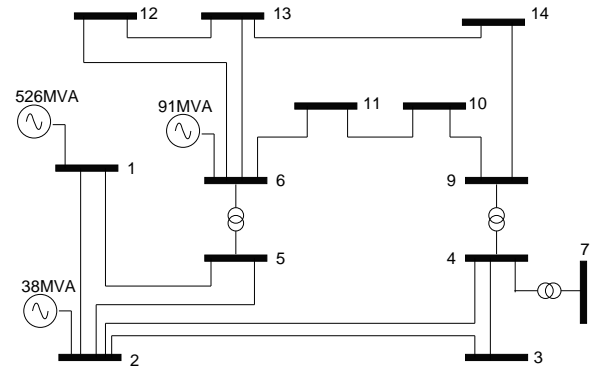

Figure 1: Test model of simple transmission network, based on [2]

has been modelled. The test network, shown in Figure 1, is based on the benchmark 14-bus balanced transmission system proposed by [2]. A purely inductive network model has been implemented; for clarity, capacitive and resistive elements have been discarded at this stage. Network parameters are given in the Appendix. The locations and capacities of generating units have been assumed to be fixed. The test network is used as a case study in Section 7 to demonstrate the feasibility of area-based allocation.

2. OVERVIEW OF PRESENT HARMONIC ALLOCATION METHODOLOGY

Harmonic allocation in Australian transmission networks is governed by the standard AS/NZS61000.3.6 [1], which provides general principles and a method of calculating harmonic emission levels for any connected load. The h th harmonic voltage E_{Uhi} allocated to a load i at its point of common coupling (PCC) is directly related to the maximum demand S_i of that load. In order to ensure that excessive harmonic voltages do not occur at any bus, the allocation must be carried out on the entire transmission network, given that each load has the potential to give rise to substantial harmonic voltages at buses other than the PCC. This situation contrasts with that in distribution systems.

Under the principles recommended by [1], it is voltage, rather than current or any other quantity, which is being allocated to each load (proportionally to the maximum

demand S_i of the load); conversion to a current is via the network harmonic impedance at each PCC. This is in contrast with the allocation principles of IEEE Std. 519 [3], whereby current is allocated to each load directly, depending on the ratio of the load demand to the fault level at the PCC. As [1] is the binding standard in Australia [4], attention in this paper is directed towards it rather than towards [3].

Present allocation methods based upon [1] require detailed knowledge of every load on the network in order to determine emission levels for even a single load. No such constraint is imposed by [3]. Area-based allocation is intended to overcome this difficulty.

A method for accounting for the interactions between buses is given in [1]. Previous work [5] has shown that this procedure can give unsatisfactory results, in that it can lead to harmonic voltages in excess of planning levels $L(h)$ when all loads inject the calculated currents. Only a minor modification to the allocation procedure is required to rectify this state of affairs: if $V_j(h)$ is the harmonic voltage arising at bus j when each load takes its full emission level, then the constraint

$$V_j(h) \leq L(h) \quad (1)$$

can be explicitly forced. This is the method which will be applied in this paper.

3. MOTIVATION FOR AREA-BASED HARMONIC ALLOCATION

Several characteristics of transmission networks make area-based harmonic allocation techniques worthy of investigation.

Firstly, the loading level which may be connected at any particular bus at some future time is rarely known with any significant degree of precision. Results and further discussion in Section 4.1 will demonstrate that the loading at a busbar can vary over several orders of magnitude. Expanding the region of interest from individual buses to an area means that less knowledge is required of future loading at any one bus, making a realistic allocation easier to achieve.

Secondly, in many cases a load will have no need for part or all of the allocation to which it is entitled. The ability to transfer surplus allocation to a nearby distorting load would allow the harmonic capacity of the network to be utilised more efficiently. Transfers would be much more easily accomplished within discrete areas.

Thirdly, it is reasonable to expect that the precision of a harmonic allocation should be directly related to the precision of data available with which to carry out the allocation. The parameters and configuration of the network can vary substantially as operating conditions (such as generating unit commitment) change, implying that the emission level calculated for any particular customer should not be tightly specified.

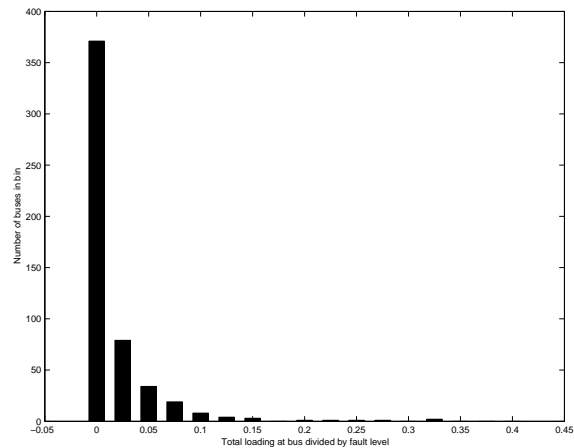

Figure 2: Histogram of loading divided relative to fault level for buses in two Australian transmission networks

Percentage of fault level to which buses are loaded	Proportion of buses in network
0%	63.0%
$\leq 2.0\%$	75%
$\leq 5.3\%$	90%
$\leq 7.7\%$	95%
$\leq 12\%$	98%
$\leq 20\%$	99%
$\leq 34\%$	100%

Table 1: Summary statistics for data in Figure 2

Finally, in the case of very large loads, where a customer is fed by multiple separate supplies from nearby buses, it is reasonable that the allocation ought not distinguish between the supplies. An area-based method would eliminate any such distinction, by hiding any difference in network impedance seen by the separate supplies.

4. PROBLEMS WITH BUS-BY-BUS ALLOCATION

4.1. DETERMINATION OF DEFAULT BUS LOADING

Figure 2 is a histogram showing loadings at different buses, relative to the fault level at each bus, modelled with data from two separate Australian transmission networks.

Whilst the vast majority of buses are not loaded at all, several others are loaded up to around one quarter or one third of the fault level. Table 1 gives key summary statistics from the Figure 2 data.

As Table 1 indicates, prediction of the future loading at any particular bus in a transmission network is virtually impossible. Substantial variations in relative loading can be observed from bus to bus. For example, even though Table 1 shows that 90% of the buses in the two networks considered are loaded no higher than 5.3% of the fault level, at least one bus exists which is loaded to 34% of

the fault level.

In contrast to the loading at individual buses, the future summated loading on the entire network can be predicted to a reasonable level of accuracy. However, allocating to the summated network load would be impractical and would not yield useful information. A compromise is required between an allocation method based on loading levels at individual buses and an allocation method based on the entire network load.

A suitable method of handling buses which are presently not loaded is required for harmonic allocation. It is reasonably likely that at some stage loads will be connected at buses which are presently unloaded. These new loads ought reasonably to be entitled to non-zero harmonic emission levels.

This problem leads to the question of how an appropriate default future loading might be chosen. The present maximum value is an unsuitable choice, as it would unfairly disadvantage existing large loads and almost certainly give far too much allocation to small or potentially zero loads. Also unsuitable is the median: the median load relative to fault level is zero for the buses in Figure 2. This implies that the mean is also likely to be an unreliable estimate, as it will be influenced substantially by a small number of very large loads.

For the purposes of this exercise, we choose (as a reasonable compromise) the 90th percentile load, relative to the fault level, to be the estimated future load at any bus on the network, except at buses which are already loaded beyond this value; such bus loadings remain unchanged. From the data in Figure 2, the 90th percentile is a loading of 5.3% of the fault level.

4.2. IMPACT OF ALLOCATION

Suppose that the default 5.3% loading is extrapolated to the test network described in Section 1. Performing a harmonic allocation exercise using the method outlined in Section 2 then entitles the future load at bus 1 to a greater harmonic voltage emission level (0.95% at the 5th harmonic) than the existing load at bus 3 (0.93%). Furthermore, the permitted contribution by the future load at bus 1 to the harmonic voltage at bus 3 is as high as 75% of the harmonic voltage allocated to the existing large load at bus 3. This situation is not an appropriate allocation, given that bus 3 is by far the most heavily-loaded bus on the network, whilst bus 1 is presently unloaded. The anomaly arises because of a much larger fault level at bus 1 than at bus 3, meaning that the future allocated load at bus 1 can be quite high.

The division of the network into areas will facilitate compromise between the unnecessarily small allocation derived when allocating bus by bus and the impracticality of allocating to a single equivalent summated load for the entire network.

5. A POSSIBLE AREA IDENTIFICATION METHOD

5.1. AREA DEFINITION

Suppose buses m and n both lie in area \mathcal{A} and that a harmonic current $I(h)$ is injected into the network at bus m . Then the harmonic voltage $V_{x,m}(h)$ developed at any bus x should approximate the harmonic voltage $V_{x,n}(h)$ which would have arisen had the injection $I(h)$ been at bus n instead. That is,

$$|z_{xm}(h) - z_{xn}(h)| \leq d_{app} \quad (2)$$

where $z_{ij}(h)$ is the ij th element of the network impedance matrix $Z(h)$ at the h th harmonic and d_{app} is a small tolerance which is not necessarily known *a priori*.

Then, when attempting to group two buses into a single area, the objective should be to minimise, in some sense, $|z_{xm}(h) - z_{xn}(h)|$, in order that there should be little distinction between injecting harmonic current at bus m and injecting at bus n .

There is a trade-off between the number of areas n_a into which the network is to be grouped and the degree to which buses can be assumed to lie within the same area, indicated by d_{app} . Specification of a formal algorithm for area identification without at least an estimate of either n_a or d_{app} is not possible. Intuitively it might be expected that n_a would be of the order of the square root of the number of buses in the network.

5.2. MAPPING OF BUSES INTO AREAS

There are many possible calculation methods to find area boundaries. The method given in this section is just one solution.

Let n_b be the number of buses in the transmission network.

Firstly, the $n_b \times n_b$ network harmonic impedance matrix $Z(h)$ is to be found. Then, equation (2) can be used to identify an $n_b \times n_b$ test matrix T , with individual elements

$$t_{mn} = E \left(\frac{(z_{xm}(h) - z_{xn}(h))^2}{|z_{xm}(h) \cdot z_{xn}(h)|} \right) \quad (3)$$

where $E(\cdot)$ is the expected value operator for integers x from 1 to n_b . Division by $|z_{xm}(h) \cdot z_{xn}(h)|$ in equation (3) is to ensure that each pair of buses under consideration is weighted equally.

An initial estimate of the maximum acceptable tolerance d between intra-area buses must be made. In the present case, 10% was selected as appropriate. That is, if t_{mn} is no more than (initially) 10% then m and n are assumed to lie within the same area. A bus-matching matrix A can be constructed, with elements a_{mn} defined as

$$a_{mn} = \begin{cases} 1, & \text{if } t_{mn} \leq d \\ 0, & \text{otherwise} \end{cases} \quad (4)$$

Every non-zero a_{mn} implies that m and n lie within the same area.

If d has been chosen to be large enough to identify multiple buses within a single area, then A will be singular and of rank $n_a < n_b$, where n_a is the initial estimate of the number of areas in the network (otherwise, A would simply be the $n_b \times n_b$ identity matrix). If insufficient areas are identified, then the process can be repeated with an increased value of d and vice versa, until both the number of identified areas and the tolerance are within acceptable boundaries.

When an acceptable A has been arrived at and n_a has been updated accordingly, A can be converted into reduced row echelon form in order to remove redundancy. The first n_a rows of the reduced row echelon form are to be retained as the area mapping matrix A' ; remaining rows are all zeros and can be discarded. The rows of A' are a representation of the buses making up each area, that is, A' maps areas to bus numbers and is of size $n_a \times n_b$.

It remains to develop a many-to-one map to relate each bus number to the area in which it is located. Assuming that areas are numbered sequentially from 1 to n_a , such a mapping can be found by

$$C = (B \cdot A')^{\text{tr}} \quad (5)$$

where

$$B = \begin{pmatrix} 1 & 2 & \dots & n_a \end{pmatrix} \quad (6)$$

and tr denotes the matrix transpose operator. If different area designations are desired, an alternative vector B can be chosen, provided that every element is unique. The i th element of n_b -length vector C is the area in which bus i has been determined to lie.

6. HARMONIC ALLOCATION TO IDENTIFIED AREAS

6.1. CALCULATION OF AREA LOADINGS

Once the areas within a transmission network have been established, allocation cannot proceed until an expected loading is determined for each area.

The most straightforward solution is to simply add up the projected loads — determined as per Section 4.1 — at all buses within the area. Whilst this method is easy to apply, it eliminates many of the benefits of the area-based approach to allocation.

Noting, however, that the 90th percentile load — that is, the value of load S such that the probability of the total actual load being no more than S is 90% — was chosen at each bus, it seems reasonable to choose a 90th percentile load at each area as well. This can be accomplished by numerical means once the number of loads in the area is known. One such method is detailed further in Section 7; the most appropriate method will

Number of loads in area, n_v	(90th percentile of summated loads) divided by ($n_v \times$ 90th percentile bus loading)
2	0.94
3	0.94
4	0.83
5	0.71

Table 2: Expected load within area relative to summated expected load at individual buses, when all buses in area are at equal fault levels

depend upon the numbers of buses and areas in the transmission network.

Even if all buses within an area are at the same fault level, the calculation of the 90th percentile area load depends on the statistical distribution of load at individual buses making up the area. If the distribution shown in Figure 2 is assumed to be typical of a transmission network, then it is safe to assume that the 90th percentile load for an area will be smaller than the sum of 90th percentile loads at buses forming that area, as the distribution is heavily weighted towards small loads.

To verify this proposition, experimentation was carried out using a discrete 15-bin approximation to the distribution in Figure 2. 1000 samples of n_v random load variables were created, where n_v denotes the number of loads in an area. The 90th percentile of the sum (representing a net area load) was compared with the sum of n_v 90th percentiles (representing the total load within an area). For different numbers of loads within an area, the ratio of these two quantities was calculated; the results appear in Table 2. From Table 2 it can be concluded that the area-based network representation enables allocation to be made to smaller total loads than are necessary under a bus-by-bus allocation. Furthermore, increasing the number of buses within each area increases the benefit gained through the area-based approach.

6.2. ALLOCATION TO AREAS

In order to perform a harmonic allocation using the area-based method, areas must be first identified, using the method described in Section 5 or an alternative procedure. All transmission lines and other series elements within each area are to be discarded.

Noting that generators can be modelled as passive shunt elements at harmonic frequencies [6], passive shunt elements within an area should be combined into a single equivalent element. Present investigations have been confined to purely inductive network representations; complications may arise when shunt capacitances are considered.

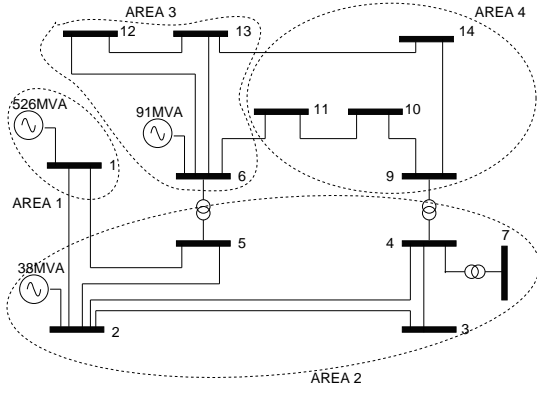

Figure 3: Division of test network into areas

Area	Net load attributed to area (MVA)	Sum of individual loads within area (MVA)
1	123	123
2	287	320
3	75.9	104
4	60.3	60.3

Table 3: Results of combining buses in test network into areas

7. APPLICATION OF METHOD TO A SAMPLE NETWORK

This section describes the implementation of area-based allocation on the simple test network shown in Figure 1. Investigation is confined to the 5th harmonic but can be easily extended to other frequencies.

Application of the technique described in Section 5.2 yields the areas shown in Figure 3.

These distinctions were identified using a cutoff of $d = 10\%$, giving $4 \approx \sqrt{n_b} = \sqrt{13}$ areas. With this cutoff, areas were derived via the bus-matching matrix A and the area mapping matrix A' , shown graphically in Figures 4(a) and 4(b) respectively.

Many possible methods of calculating the effective load within an area exist. The method described here is one possibility, and is similar to the experiment carried out at Section 6.1. For each bus, 1000 random samples were created on the basis of the distribution in Figure 2. Each sample was multiplied by the bus fault level, to give a sample MVA loading at the bus. At already heavily-loaded buses (where the existing loading level exceeds the 90th percentile of 5.3% of the fault level, namely at buses 3, 4, 9, 10 and 14), the existing MVA loadings were substituted. Corresponding samples were summed for all buses within each area, and each 90th percentile MVA area load was determined from the 1000 summated samples.

Table 3 shows the load calculated for each area. For comparison purposes, the sum of the calculated individual bus loads is also shown. It can be seen from the table that the area-based approach allows for allocation to be made to a smaller net load in areas 2 and 3 than

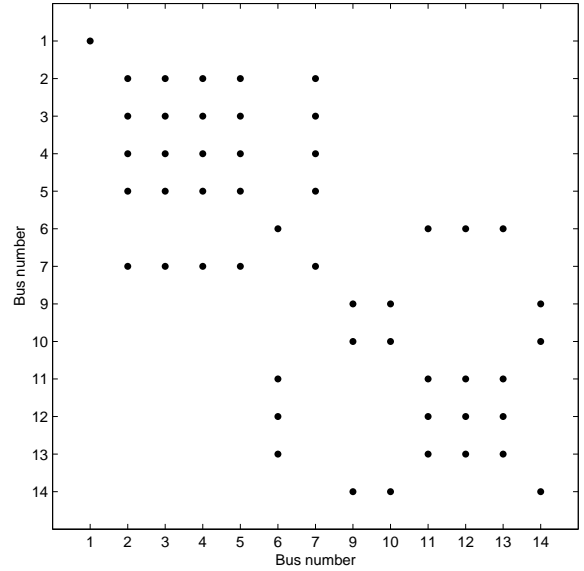

(a) Bus-matching matrix A

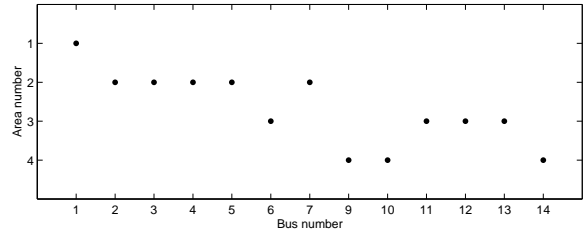

(b) Area mapping matrix A'

Figure 4: Mapping matrix structures (markers represent ones; spaces represent zeros)

Area	5th harmonic voltage emission level E_{U5} (%)
1	0.89
2	1.6
3	0.63
4	0.53

Table 4: 5th harmonic voltage emission levels in each area

would be the case if allocation were carried out on a bus-by-bus basis. This is especially true of area 3, where all buses are loaded only lightly. No reduction in net load occurs in area 1 as it contains only one bus; in area 4 each bus is sufficiently heavily loaded that the 90th percentile approximations do not apply. The reductions in net load identified through the area-based approach mean that the harmonic absorption capacity of the network can be more fully utilised, leading to less restrictive harmonic emission levels across the network. It is reasonable to expect that in a real transmission network, where many more buses can be combined into a single area, the gains from the area-based approach will be substantially greater.

With the areas and corresponding loading levels determined for the sample network, the actual allocation can proceed. Voltage emission levels calculated for each area at the 5th harmonic, using the method outlined in Section 2, are given in Table 4.

8. CONCLUSIONS

Area-based allocation represents a feasible means of overcoming the dependence of a harmonic allocation upon accurate knowledge of load locations and magnitudes, and of providing harmonic emission levels which are not unduly constrained by the need to allow for possible substantial load at all busbars. Results have demonstrated that area-based allocation can allow the harmonic absorption capacity of the network to be more fully utilised than would be the case using existing methods.

The investigation into area-based allocation documented in this paper has led to the development of a method for identifying area boundaries from the network harmonic impedance matrix. Techniques have been devised for determining measures of the load within an area.

Further work is required to:

- identify the most appropriate way of assigning load to an area, and to determine the impact of the number of buses in an area on the optimum loading to be selected for that area;
- investigate the feasibility of using area-based allocation to overcome uncertainty in parameters other than loads, for instance in generating unit commitment;
- examine the effects that uncertainty in inter-area equipment parameters will have upon the harmonic allocation: with far fewer components being modelled under the area-based approach, variations in any one component can be expected to make a substantial difference to the final harmonic allocation;
- formalise a procedure for handling multiple harmonics; and
- investigate the appropriateness and feasibility of area-based allocation under more detailed network modelling, including shunt capacitances from transmission lines and power factor correction units.

9. ACKNOWLEDGMENTS

The authors are grateful for the support of Powerlink Queensland in this work.

REFERENCES

- [1] *Electromagnetic compatibility. Part 3.6: Limits–Assessment of emission limits for distorting loads in MV and HV power systems (IEC 61000-3-6:1996, MOD)*, Standards Australia Australian/New Zealand Standard AS/NZS 61 000.3.6:2001.
- [2] R. Abu-Hashim, R. Burch, G. Chang, M. Grady, E. Gunther, M. Halpin, C. Harziadonin, Y. Liu, M. Marz, T. Ortmeyer, V. Rajagopalan, S. Ranade, P. Ribeiro, T. Sim, and W. Xu,

“Test systems for harmonics modeling and simulation,” *IEEE Trans. Power Delivery*, vol. 14, no. 2, pp. 579–587, Apr. 1999.

- [3] *IEEE Recommended Practices and Requirements for Harmonic Control in Electrical Power Systems*, IEEE Industry Applications Society / Power Engineering Society IEEE Std 519-1992.
- [4] *National Electricity Code*, National Electricity Code Administrator Limited Version 1.0 - Amendment 9.0, 29 Oct. 2004.
- [5] T. Browne, V. Gosbell, and S. Perera, “Allocation of harmonic currents to customers in meshed HV networks,” in *Australasian Universities Power Engineering Conference*, Christchurch, New Zealand, Oct. 2003.
- [6] J. Arrillaga, B. C. Smith, N. R. Watson, and A. R. Wood, *Power System Harmonic Analysis*. Chichester, UK: John Wiley & Sons, 1997.

APPENDIX

The simple 230/115kV test network given in Figure 1 is derived from the 14-bus transmission system proposed for harmonic analysis in [2]. Various parameters have been adjusted to assist in demarcating areas clearly. Reactances of 0.25pu have been assumed for all generators. Line reactances, transformer reactances and initial loads for the test network are given in Tables 5, 6 and 7 respectively. It should be noted that specific load values are utilised in Section 7 for only the larger loads.

Bus 1	Bus 2	X_{ser} (pu on 100MVA)	Bus 1	Bus 2	X_{ser} (pu on 100MVA)
6	11	0.13887	1	2	0.23664
6	12	0.12788	1	5	0.22300
6	13	0.13024	2	3	0.19794
9	10	0.08448	2	4	0.17628
9	14	0.27033	2	5	0.17384
10	11	0.76808	3	4	0.17099
12	13	0.19985	4	5	0.04209
13	14	1.39180			

Table 5: Line parameters for test network

Bus 1	Bus 2	X_{ser} (pu on 100MVA)
4	7	0.001
4	9	1.11236
5	6	0.5004

Table 6: Transformer parameters for test network

Bus	MW	MVA _r	Bus	MW	MVA _r
3	59.505	3.363	10	9.000	5.799
3	59.505	3.363	11	3.500	1.800
4	47.790	-3.900	12	6.099	1.599
5	7.599	1.599	13	13.500	5.799
7	0.000	12.900	14	14.901	5.001
9	29.499	16.599			

Table 7: Load parameters for test network