

# Design of a Light Chamber for the Characterisation of Flicker Behaviour of Lamps

John Braun  
Integral Energy Power  
Quality and Reliability Centre  
University of Wollongong  
NSW2522, Australia  
[jbraun@ieee.org](mailto:jbraun@ieee.org)

Sarath Perera  
Integral Energy Power  
Quality and Reliability Centre  
University of Wollongong  
NSW2522, Australia  
[sarath@uow.edu.au](mailto:sarath@uow.edu.au)

Vic Gosbell  
Integral Energy Power  
Quality and Reliability Centre  
University of Wollongong  
NSW2522, Australia  
[vgosbell@uow.edu.au](mailto:vgosbell@uow.edu.au)

## ABSTRACT

*This paper presents the design of a light chamber which can be used to investigate the flicker behaviour of various types of lamps. Using this system, a lamp can be subjected to a controlled voltage waveform while current and illuminance of the lamp are monitored. With the aid of such a voltage source capable of generating voltage fluctuations, including interharmonics and other power quality disturbances, the relationship between waveform and light flux fluctuation can be modelled. Such a system can be easily built with off the shelf equipment, but the cost would be prohibitive. To circumvent this problem, the design has been based on a combination of custom hardware, generic hardware and the LabVIEW software. The paper focuses on the various trade offs of the design as well as its initial usage with incandescent lamps and shows the how the system can be used for the verification of the model that describes the flicker behaviour of the lamp.*

## 1. INTRODUCTION

The flicker behaviour of a lamp is traditionally described by its gain factor [1] which expresses the relative change in the light level to a change of power supply voltage. The gain factor is given for a given frequency of the voltage fluctuation. At low fluctuation frequency the gain factor is typically between 3 and 4 for a 60W incandescent lamp and between 0.5 and 1.5 for a 36W fluorescent lamp [2].

Because of the higher sensitivity of incandescent lamps to voltage fluctuation, the IEC flickermeter [3] was based on a 60W incandescent lamp. This choice was also dictated by the fact that the 60W incandescent lamp was the most commonly used lamp at the time of the conception of the flickermeter. However, with possibility of the increase in the level of interharmonic levels in power systems, it has been realised that fluorescent lamps are capable of exhibiting flicker at interharmonic frequencies for which an incandescent lamps are insensitive [4]. In some cases flicker could be observed on fluorescent lamps, but not on incandescent lamps [5]. In such a situation, the IEC flickermeter does not measure the proper flicker level.

The design of a flickermeter capable of indicating the correct flicker level for a fluorescent lamp requires a flicker model suited for this type of lamp. Such a model

should be capable of predicting the fluctuation of the light level of a fluorescent lamp from the voltage across the tube. In the case of the incandescent lamp, this model is a squarer followed by a low pass filter. While this model was established early in the twentieth century [6], no simple model is yet available for fluorescent lamps.

The establishment of a flicker model for the fluorescent lamp is conditional to its verification through a comparison of the model prediction with the actual change of light level of the lamp. This requires test equipment capable of producing voltage waveform with controlled parameters as well as a system to monitor the resulting light illuminance of the lamp. Sophisticated off the shelf programmable power supplies capable of generating most power quality disturbances are well suited for such applications. However, costs of such systems are prohibitive. The design of the light chamber presented in this paper incorporates National Instruments acquisition cards and LabVIEW as well as a linear power amplifier developed in house.

The paper is organised in three sections. Section 2 outlines the key requirements of the measurement system while Section 3 describes the design itself. Section 4, presents practical measurements made on incandescent lamps.

## 2. SYSTEM DESCRIPTION

Figure 1 shows the block diagram of the light chamber system. The system has two modes of operation: namely, waveform recording and investigation of lamp behaviour. The three main components of the system are the light chamber, the voltage adaptor and the PC. Together they permit the recording of typical voltage waveforms from the field, which can be used to drive the lamp using the amplifier and monitor its voltage, current and illuminance.

When the system is used for the acquisition of real world waveforms in the field, only the voltage adaptor and the PC are used. Together, they permit the recording of waveforms in location known for the presence of power quality disturbances and allow their replay in a laboratory environment. The voltage adaptor can be used both in three and four wire systems and attenuates incoming voltages (eg. from an instrument transformer) into a level suitable for the ADCs in the PC card. The voltage adaptor also provides galvanic isolation and protection against high voltage transients.

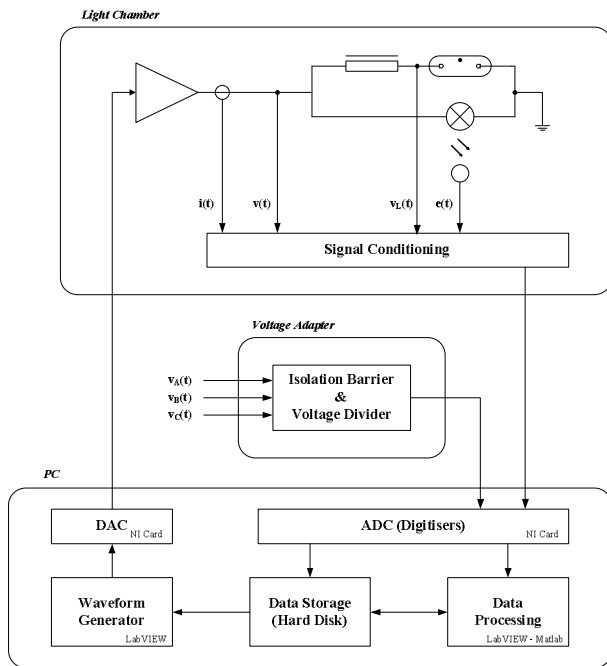

Figure 1: Light chamber system

The PC is the heart of the system in both modes of operation of the system. The PC is fitted with one card containing four 16 bit ADC with a common clock allowing simultaneous sampling as well as a 16 bit DAC card whose sampling clock is supplied by the ADC card. This permits synchronisation of the DAC to the ADCs. The sampling rate is set by the user and can be as high as 220 kSPS. A 16 bit system is required to ensure good resolution with flicker measurements. The hard disk is used for the storage of waveform files or acquired light chamber signals. The LabVIEW and MATLAB are capable of processing the waveform either in real time or in batch mode.

In acquisition mode, the speed and capacity of the hard disk are very important. With a sampling rate of 10 kSPS, the recording of a three phase system generates about 59 kBytes per second which must be stored in the hard disk. The duration of the recording determines the hard disk capacity. An hour of recording will produce about 206 MBytes while a full day produces about 4.82 GBytes. While these size requirements are consistent with capabilities of modern hard disks, longer recording may require the usage of multiple hard disks.

When used in the lamp investigation mode, the PC is used to stimulate the lamp as well as to process or store signals received from the light chamber. The waveform sent to the light chamber is either synthesised in real time or a replay of stored real world waveforms captured from the field. The need for the creation of waveforms in real time is dictated by the presence of interharmonics which could lead to non-periodic signals. The ADCs used by the voltage adapter are also used for the four signals originating in the light chamber, namely the waveform of voltage supplied to the lamp, the voltage across the fluorescent tube, the current through the lamp and the illuminance captured by the light sensor. The voltage across and current through the lamp are sensed

using a non inductive voltage divider and a current shunt respectively.

The light chamber is made so that no external light enters it. Its dimensions are approximately 150cm x 50cm x 60 cm which are dictated by the size of 36W fluorescent lamp fitting and by the need to place the light sensor at some distance from the lamp to ensure that the lamp acts as a quasi-isotropic point source. A 150W power amplifier capable of driving either incandescent or fluorescent lamps is also mounted within the light chamber.

Similarly to the voltage adaptor, precautions must be taken to ensure a galvanic isolation with the PC. This is achieved by the use of isolation amplifiers whose bandwidth ranges from DC to a few kHz. These isolation amplifiers provide galvanic isolation for all signals entering or leaving the light chamber.

The bandwidth of the amplifier must be sufficient to ensure amplification of waveforms causing visible flicker. While the eye is capable of perceiving flicker of up to 35Hz, the spectrum of the waveform depends of the nature of the flicker. In the case of amplitude modulated fundamental, the significant components occur in the range from 15 Hz to 85 Hz. While a DC limit is not strictly required, any attenuation or phase shift on these components can attenuate the flicker. Another important requirement of the amplifier is the need for low distortion so as to avoid the introduction of unwanted harmonics which could lead to an increase of the flicker in the presence of interharmonics in the waveform. In the case of an incandescent lamp, the simultaneous presence of harmonics and interharmonics can result in beat in the visible to the human eye.

The photometer used in the light chamber must also comply with several requirements. The first is the need for its spectral response to be matched to the photopic vision of the human eye. This response is referred as the spectral luminous efficiency curve (Figure 2) which has been established in 1924 [7] by the CEI (Commission Internationale de l'Eclairage). Another requirement is the need for a correction for possible measurement error when the light reaches the detector with a high angle of incidence [7]. This so called "cos correction" and is achieved by placing a diffusing filter on top of the photometer. The useful range of the photometer shall be between 5 and 10 kLux with a low noise floor.

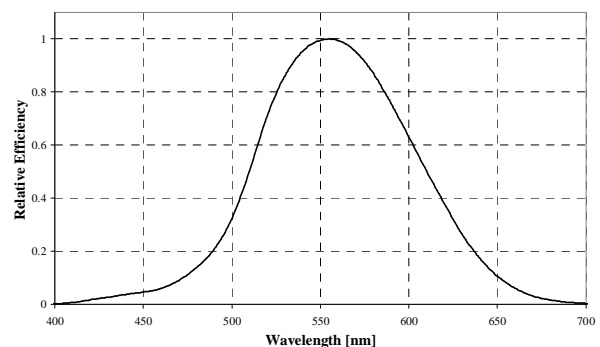

Figure 2: CEI Spectral luminous efficiency curve

### 3. DESIGN OF THE LIGHT CHAMBER

At the core of the design of the light chamber is the need for a power supply capable of producing 50 or 60Hz waveform containing fluctuations, harmonics and interharmonics capable of handling about 150W. While sophisticated programmable power supplies fulfilling these requirements are available in the market, their costs are prohibitive. Another limitation observed in some of these products is their inability to generate interharmonics and flicker at very low frequencies, a limitation caused by the limited memory size of the arbitrary waveform generator generating the waveforms. The other components of the light chamber are the photometer and the sensors for the voltage and current measurement in relation to the lamp. External to the light chamber itself, are the control and computing resources permitting the creation of waveform, and the processing of the signals originating from the light chamber.

#### 3.1. POWER AMPLIFIER

The choice of an in house design has been conditioned by the difficulty in obtaining amplifiers capable of driving 230V lamps. While amplifiers with power levels up to several hundred watts are readily available, the voltage swings are generally much lower. Additionally, the cost of suitable commercial amplifiers is prohibitive thus forcing the selection of a custom design. Several design options are available for such an amplifier. Among them were the use of an audio amplifier followed by a step up transformer, a design with discrete components or with power operational amplifiers and switching amplifiers.

The easiest solution would be the use of an audio amplifier with a step up transformer. Measurements on an existing design showed two main limitations of such a design, namely the high level of distortion and the difficulty in amplifying sub-harmonics. This is further aggravated by the difficulties in implementing feedback from the load to the amplifier input. The second option of a complete design with discrete components was rejected because it was perceived to be more time consuming despite its broader options available. The availability of off-the-shelf power operational amplifier capable of working at high voltage as well as high power levels was a much more an attractive proposition as it reduced the design effort. This offered the option to choose a linear or switching implementation of the amplifier. But, despite the benefits of pulse width modulation amplifier, the former solution was selected because of its lower noise and absence of the filter design. However, this choice of linear power operational amplifier was not without issues to be resolved.

The first limitation is the difficulty in obtaining a power operational amplifier capable of operating with a supply voltage higher than +/- 200V with a current rating of 1A. With current limited to about 0.2A, some devices are capable of operating with voltages of up to +/- 250V. This limitation can be overcome with a bridge structure of the amplifier as shown in Figure 2. To circumvent the current limitation of the devices, the addition of a MOSFET push-pull stage has been investigated.

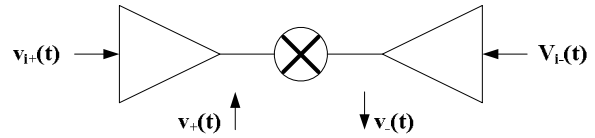

Figure 3: Amplifier with bridge structure

But, the driving of a MOSFET push-pull stage would lead to a loss of some of the usable power supply voltage. Another aspect with such an approach is the difficulty in finding complementary pairs capable of handling voltages above 500V. Transistor stages capable of handling full current with a drain-source voltage equal to the rail to rail voltage are required for highly reactive loads such as fluorescent lamps.

To reduce the design effort, a device capable of handling higher current with a voltage limit of 200V was selected. With a power supply of +/- 195V the achievable peak to peak is 365V corresponding to a sinusoidal waveform of  $258V_{rms}$ . This corresponds to a margin of 12% for a nominal voltage of 230V. This has been judged acceptable which implies that care must be exercised in the case of higher than nominal voltage and or in the presence of harmonics that introduce high peak voltages. Should some experiment require such high values of voltage, the experiment can then be undertaken with lamps operating at 120V / 60Hz. The significant benefits of this design option are simplicity and flat frequency response between DC and 5 kHz.

Although it is well known that linear amplifiers have an efficiency limited to 50%, the driving of a reactive load can further degrade the performance and efficiency can even reach 0% when a pure inductor or capacitor is used as a load. With a power factor around 0.5, inductive or capacitive, fluorescent lamps force high power dissipation in the amplifier which demands the use of a very efficient heat sink requiring two fans directly mounted on it. This also forced the use of two power ICs for each branch of the bridge as shown in Figure 4.

Another problem associated with reactive loads is the potential risk of instability in the amplifier. With a power factor around 0.5, fluorescent lamps introduce an additional pole in the feedback loop when combined with the internal impedance of the operational amplifier. Fortunately, in the present design, this impedance is very small in comparison to the resistive component of the lamp itself. This forms a lead-lag circuit where the pole and zero are very close and thus are not very critical.

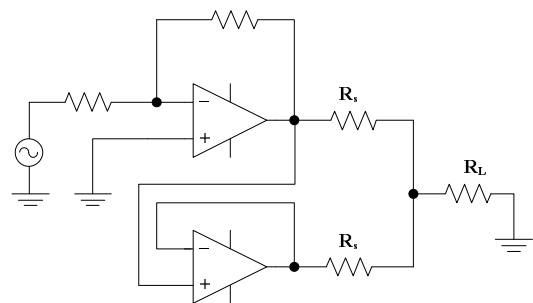

Figure 4: Parallelisation of power op-amps

### 3.2. LIGHT PROBE

The search of a suitable light sensor has led to the selection of a modified off the shelf device. The design of illuminance meter that is both compliant to the CEI response (Figure 2) and is cosine corrected requires three components: a photodiode, light filters and a diffusion filter for the cosine correction. While photodiodes are easily available, the filters are less common and hard to obtain in small quantities. In addition, the assembly of all these components requires some machining. As an alternative to an in-house design the availability of the commercial product has been investigated. However, it has been noticed that most of these products are designed for lighting applications or for laboratory applications. While the former is generally designed for variation in illuminance at less than 10 Hz, the latter is much more costly. While photodiodes have response speeds exceeding the need of environmental applications, manufacturers tend to limit their response time by electronic means. This has led to the selection of a good quality illuminance probe used in automatic weather stations whose frequency response was modified to 570 Hz by the manufacturer. This results in negligible magnitude and phase error in the observation of visible flicker. The probe provides a voltage output of 0.3V for an illuminance of 25 kLux.

### 3.3. CONTROL AND COMPUTING

The use of standard acquisition and control cards from National Instruments together with LabVIEW as the core of the system greatly simplified its implementation. The two cards used contained respectively four synchronised ADCs for the acquisition of waveform and two DACs for the generation of the waveform required to drive the lamp. Synchronisation of both ADCs and DACs was achieved by the use of a common system clock. This permits the use of all data samples for computation without prior resynchronisation. The LabVIEW software opened the way to full programmability of the system through its block diagram program methodology thus removing the lengthy coding required for a specific test. LabVIEW is used for the generation of the stimulation waveform of the lamp, the acquisition and storage of waveforms and for the sequencing of the experiments.

A further advantage is the possibility to call Matlab scripts from within Lab VIEW. This allows the use of Matlab mathematical and signal processing libraries for the processing of acquired data. Additionally, this processing can be done in real time thus allowing the real time comparison between acquired illuminance and the prediction of the lamp's flicker model being computed from the voltage waveform across the lamp. Another possible application is the power quality processing of captured waveforms from the real world. A prime application is the comparison of various power quality algorithms with synthetic or field waveforms. A specific example is the comparison of IEC flickermeter with a version capable of registering the light fluctuation of fluorescent lamps. Another application would be the verification of an existing flickermeter subjected to either synthetic or real waveform whose readings are compared with those of a known algorithm.

## 4. RESULTS

This section presents the results from the initial application of the light chamber. While the actual characterisation of lamps is beyond the scope of this paper, the presented examples have been chosen to illustrate the suitability of the design.

The data presented have been captured with an 8 bit digital oscilloscope at the output of the light chamber as LabVIEW code was still being implemented.

### 4.1. 60W INCANDESCENT LAMP WITH NO FLICKER

Figure 5 shows the voltage and illuminance of a 60W incandescent lamp with no fluctuations in the applied voltage to the lamp. The power frequency is 50Hz and the nominal voltage 230V. These parameters will remain identical for all the measurements presented in this paper. The light probe is placed 30cm away from the lamp. While the light intensity is inversely proportional to the square of distance, the actual position of the transducer is not critical as only the variation of the illuminance is relevant in regard to flicker. 100 Hz fluctuation is clearly visible in the illuminance which represents the change of the filament temperature for a 50Hz waveform. While this flicker is not visible, this graph nevertheless shows that the flux produced by the lamp varies by about  $\pm 11\%$  around its average level.

### 4.2. 60W INCANDESCENT LAMP WITH FLICKER

Figure 6 shows the same lamp being subjected to sinusoidal flicker while Figure 7 shows the case with square wave modulation. In both case, the flicker frequency is 10Hz and the  $\Delta V/V$  is 10%.

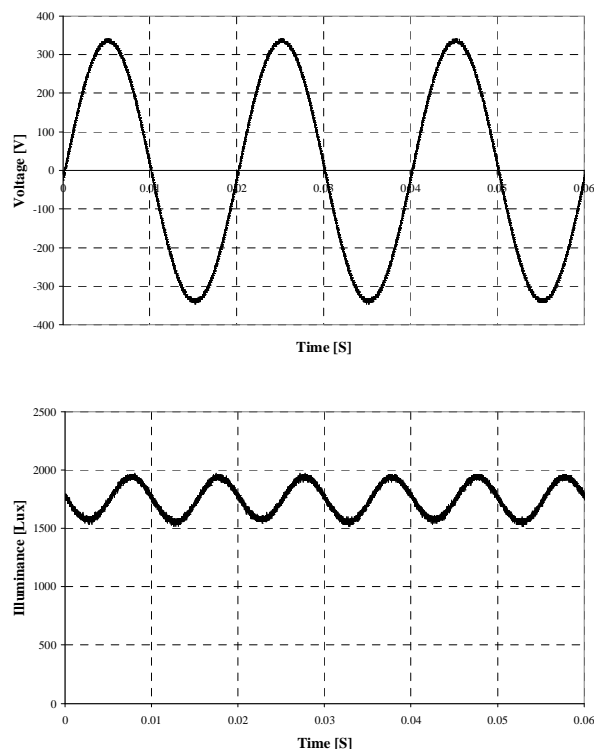

Figure 5: Voltage and illuminance for a 60W incandescent lamp in the absence of flicker

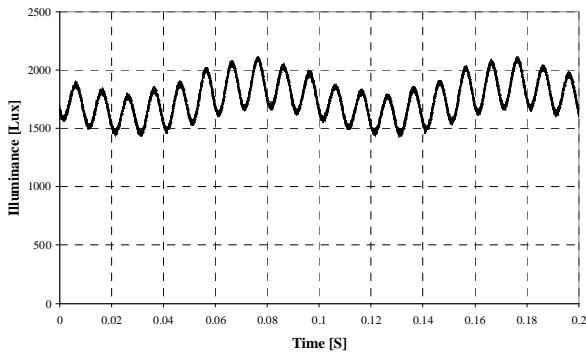
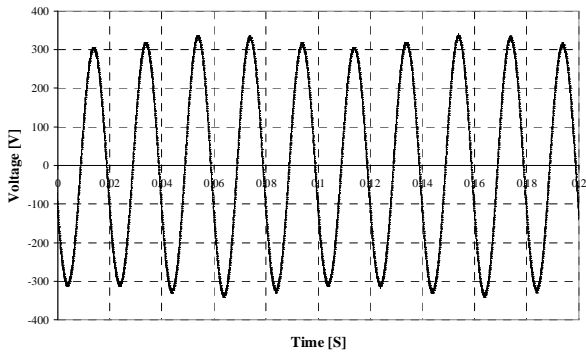

Figure 6: Voltage and illumination for the incandescent lamp with sinusoidal voltage fluctuation at 10%, 10Hz

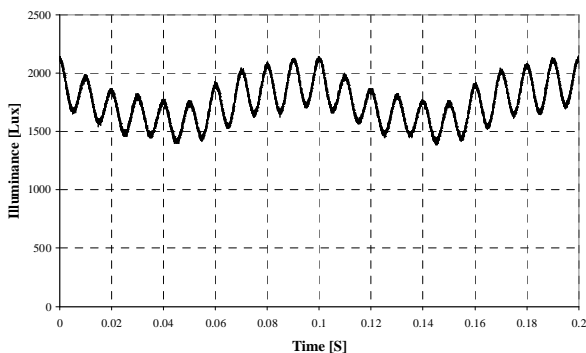
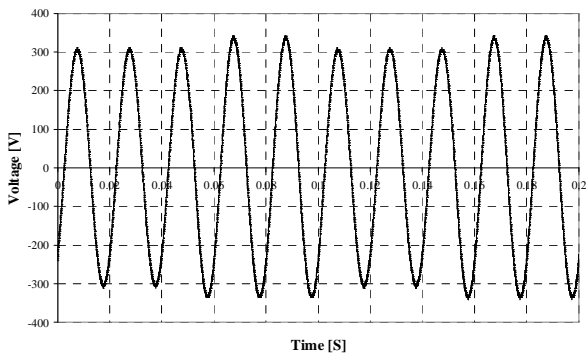

Figure 7: Voltage and illumination for the incandescent lamp with square wave voltage fluctuation at 10%, 10Hz

### 4.3. MEASUREMENT OF THE GAIN FACTOR

The gain factor for several frequencies for the 60W incandescent lamp is shown in Figure 8. This test was done with a voltage fluctuation of 5% so as to ensure small deviation of the illuminance which is consistent with the linearity assumptions of the flicker model [6].

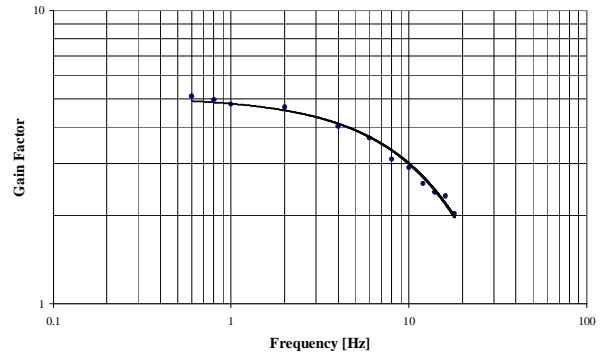

Figure 8: Gain factor for the 60W incandescent lamp

The algorithm used in the above measurement is based on the measure of the maximum and minimum of the 100Hz fluctuation during the peak and trough of the fluctuation thus removing the 100Hz component from the data. Once removed, the gain factor can be easily computed.

The Figure 8 shows the low pass filter behaviour of the lamp for the voltage fluctuation. From this, a cut of frequency of about 7.2Hz corresponding to a time constant of 22.1mS can easily be extracted. This cut off frequency is then used in the flicker model for the computation of the illuminance from the voltage as it will be illustrated in section 4.5

### 4.4. LAMP RESPONSE TO A VOLTAGE SAG

Figure 9 shows the response of the 60W incandescent lamp when a 80% sag with duration of 150mS is applied. The decay is consistent with the time constant of the lamp. After five time-constants the illuminance reaches its new steady level.

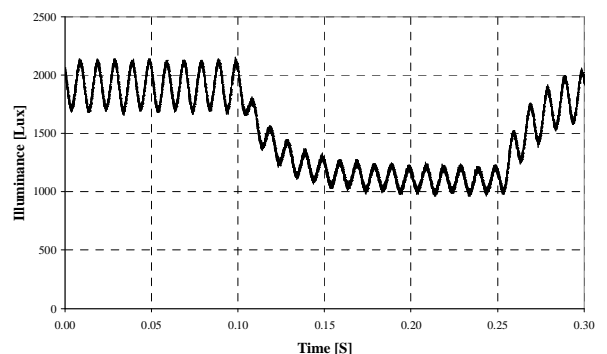
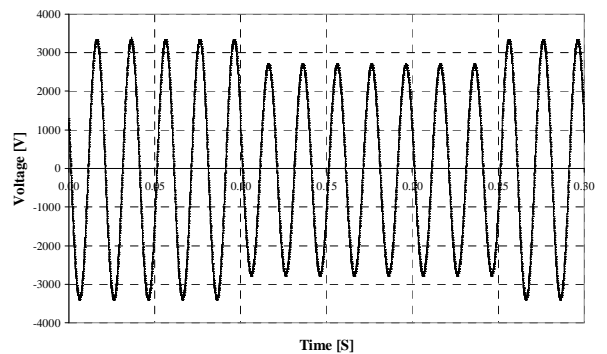

Figure 9: Lamp response to a voltage sag

#### 4.5. VERIFICATION OF A LAMP MODEL

The verification of any lamp model requires the comparison of the actual light illuminance fluctuation to the one predicted by its model. This model must naturally be valid for any voltage waveform present across the lamp. Figure 10 compares the captured waveform of voltage  $v(t)$  across of the lamp and light illuminance  $e(t)$  of the light sensor. The factor  $\alpha$  is simply a real number scaling factor used to compensate for the position of the light sensor as well for the fact that the actual model considers that all power dissipated in the lamp is converted to the visible band.

This factor is derived by using the data in Figure 5 (i.e. in the absence of flicker). The scalar  $\alpha$  is simply obtained by dividing the squared and filtered  $v(t)$  by  $e(t)$  so as to minimize the difference between the two signals. Once established, this factor is then used directly to scale the signal  $e(t)$ . Figure 11 and Figure 12 show respectively the illuminance of a 60W incandescent lamp and the illuminance predicted by its flicker model.

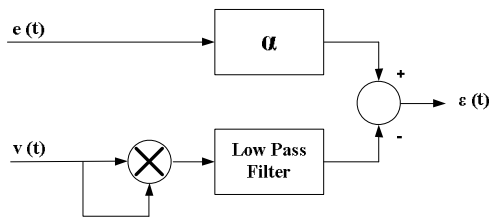

Figure 10: Verification of lamp model.

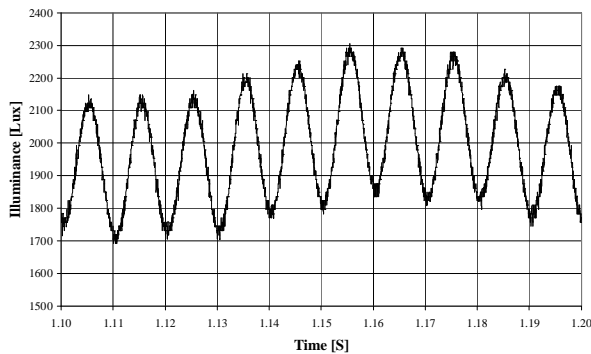

Figure 11: Illumination for the incandescent lamp with sinusoidal voltage fluctuation at 10%, 10Hz

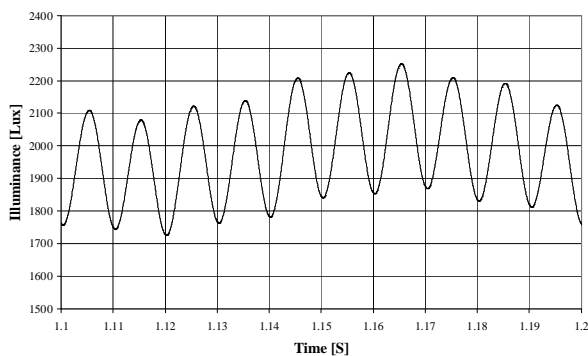

Figure 12: Illumination prediction from the flicker model with sinusoidal voltage fluctuation at 10%, 10Hz

#### 5. CONCLUSIONS

The design of a light chamber enabling the investigation of the flicker behaviour of lamps has been presented. The use of a mixture of reusable hardware, generic software, hybrid power operational amplifiers and modified commercial luxmeter probe has permitted the construction of an instrument that is both powerful and within a limited budget.

In addition to the study of the flicker behaviour of lamps, the system also permits the verification of the models representing the flicker. As lamps can be subjected to synthetic as well as pre-recorded field waveforms the resulting variation of illuminance can be compared in real time with the prediction of flicker model of the lamp as all relevant inputs to this model are acquired in the light chamber. Such verification would be of prime importance if a suitable model of a fluorescent lamp is to be established and integrated in the IEC flickermeter.

#### 1. ACKNOWLEDGEMENTS

This work was supported by GridSense Pty Ltd, Integral Energy and by the Australian Research Council under an ARC SPIRT grant. The assistance of Frank Mikk and Brian Webb with the various aspects of the construction of the light chamber is greatly appreciated.

#### REFERENCES

- [1] International Union for Electricity Application (UIE), "Guide to Quality of Electrical Supply for Industrial Installations - Part 5, Flicker and Voltage Fluctuations", 1999
- [2] W. Mombauer, *EMV, Messung von Spannungsschwankungen und Flickern mit den IEC-Flickermeter*, Berlin, VDE Verlag, 2000
- [3] IEC Standard 61000-4-15, "Electromagnetic Compatibility (EMC) – Part 4: Testing and Measurement Techniques – Section 15: Flickermeter – Functional and Design Specifications", 2003
- [4] W. Mombauer, "Flicker Caused by Interharmonics", *ETZ Archiv*, vol. 12, pp 391-396, 1990
- [5] L. Tang, D. Mueller, et al., "Analysis of DC Arc Furnace Operation and Flicker Caused by 187Hz Voltage Distortion", *IEEE Transactions on Power Delivery*, vol. 9, no. 2, pp 1098-1107 1994
- [6] I. Langmuir, "The Flicker of Incandescent Lamps on Alternating Current Circuits and Stroboscopic Effects", *General Electric Review*, vol. 17, pp 294-301, 1914
- [7] The Illuminating Engineering Society of North America, *Lighting Handbook*, New York, USA, 2000
- [8] APEX Microtechnology, "Volume 11, Power Integrated Circuits Data Book", available at [www.apexmicrotech.com](http://www.apexmicrotech.com)